



GRASSO

Refrigeration
compressors,
series RC6

Light-industrial open
reciprocating compressors for
universal application in
refrigerating, freezing, air
conditioning and heat pump
systems.

GRASSO

GRASSO PRODUCTS

**THE
SPECIALIST**

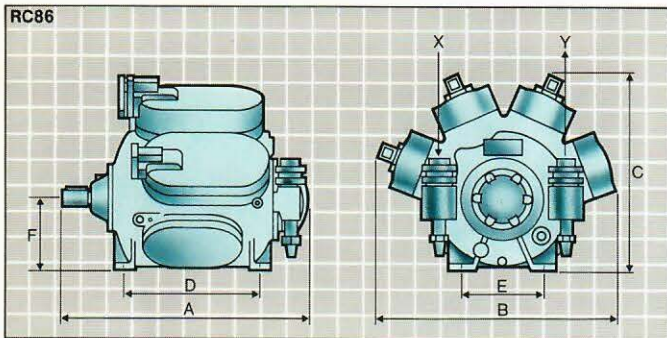
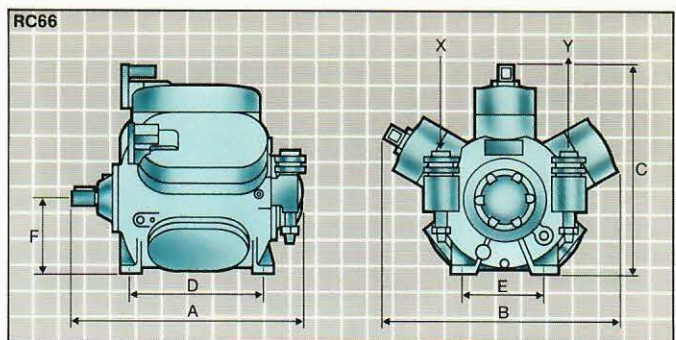
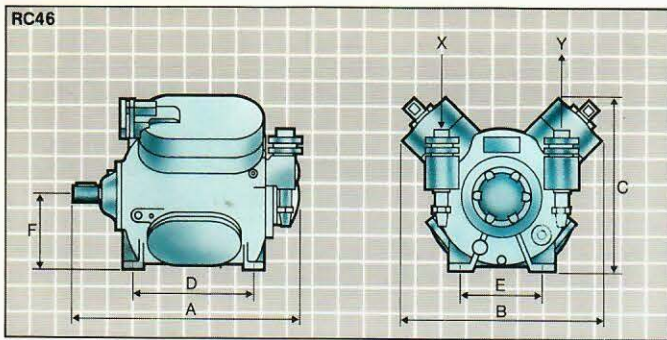

RC6 series: 3 models with 4, 6 or 8 cylinders

The RC6 series consists of 3 single-stage reciprocating compressors with 4, 6 or 8 cylinders. The type designations are RC46, RC66 and RC86 respectively.

All models can also be used as (low-pressure) booster compressors.

Apart from differences in size of compressor crankcases and crankshafts, as well as in number of cylinders, all three types are identical as far as spare parts and construction are concerned.

Technical Data

			Compressor type		
			RC46	RC66	RC86
Compressor Specification					
Number of cylinders			4	6	8
Stroke	mm			66	
Bore	mm			85	
Speed, min.	min ⁻¹			800	
max.	min ⁻¹			1800	
Direction of rotation			both directions permitted		
Swept volume at n = 1450 min ⁻¹	m ³ /h		130.3	195.5	260.7
at n = 1750 min ⁻¹	m ³ /h		157.3	236.0	314.6
Possible capacity control steps	%		25-50-75-100	33-67-100	25-50-75-100
Weight (without accessories)	kg		280	345	400
Oil charge	dm ³		9.5	15.5	17
Limits of Operation					
Discharge pressure, max.	bar (a)			26	
Suction pressure, min.	bar (a)			0.3	
max.	bar (a)			7	
Pressure difference, max.	bar			24	
Main Dimensions					
Length A	mm		696	721	746
Width B	mm		632	731	758
Height C	mm		544	644	619
Mounting holes					
C to C (4 x Ø 18 mm)	mm		394	432	444
Drive shaft height	mm		280	280	280
	mm		228	228	228
Main Connections					
Suction X	soldering connection	inch - mm	1 ⁵ / ₈ - 41.28	2 ¹ / ₈ - 53.98	2 ⁵ / ₈ - 66.68
	welding connection*	mm	48.3 x 2.6	60.3 x 2.9	76.1 x 2.9
Discharge Y	soldering connection	inch - mm	1 ⁵ / ₈ - 41.28	1 ⁵ / ₈ - 41.28	2 ¹ / ₈ - 53.98
	welding connection*	mm	48.3 x 2.6	48.3 x 2.6	60.3 x 2.9
*Outer pipe diameter x wall thickness					

$\Delta t_c = 5K$ $\Delta t_o = 10K$		RC86										SINGLE-STAGE
$n \text{ (min}^{-1}\text{)}$		800		1000		1200		1500		1800		
$t_c \text{ (}^\circ\text{C)}$	$t_o \text{ (}^\circ\text{C)}$	$Q_o \text{ (kW)}$	$P_e \text{ (kW)}$	$Q_o \text{ (kW)}$	$P_e \text{ (kW)}$	$Q_o \text{ (kW)}$	$P_e \text{ (kW)}$	$Q_o \text{ (kW)}$	$P_e \text{ (kW)}$	$Q_o \text{ (kW)}$	$P_e \text{ (kW)}$	
25	10	193.2	14.5	241.5	18.7	289.8	23.7	362.3	33.1	434.7	47.0	
	5	162.1	16.1	202.6	20.8	243.1	26.2	303.9	35.9	364.7	49.3	
	0	134.8	16.9	168.5	21.8	202.2	27.1	252.7	36.5	303.2	48.9	
	-5	110.8	17.1	138.6	21.8	166.3	26.9	207.8	35.7	249.4	46.9	
	-10	90.1	16.8	112.6	21.2	135.1	25.9	168.9	34.0	202.6	44.1	
	-15	72.1	16.1	90.2	20.1	108.2	24.4	135.3	31.7	162.3	41.0	
	-20	56.7	15.2	70.9	18.7	85.1	22.6	106.3	29.2	127.6	37.7	
	-25	43.6	13.8	54.5	17.0	65.5	20.5	81.8	26.4	98.2	34.0	
	-30	32.6	12.0	40.8	14.9	48.9	18.0	61.2	23.3	73.4	29.7	
	-35	23.6	10.0	29.5	12.6	35.3	15.3	44.2	19.7	53.0	24.7	
	-40	16.2	8.4	20.3	10.3	24.4	12.4	30.5	15.8	36.5	20.0	
	30	10	184.4	18.1	230.5	23.3	276.6	29.3	345.7	40.4	414.8	55.8
5		154.3	19.1	192.8	24.5	231.4	30.6	289.2	41.4	347.1	55.7	
0		127.8	19.4	159.8	24.7	191.7	30.6	239.7	40.8	287.6	53.7	
-5		104.7	19.1	130.9	24.2	157.1	29.6	196.3	39.0	235.6	50.8	
-10		84.6	18.5	105.8	23.1	127.0	28.1	158.7	36.6	190.4	47.4	
-15		67.4	17.5	84.2	21.7	101.1	26.2	126.3	33.9	151.6	43.8	
-20		52.5	16.1	65.7	19.9	78.8	23.9	98.5	30.9	118.2	39.9	
-25		40.0	14.3	50.0	17.7	60.0	21.3	75.0	27.6	90.0	35.4	
-30		29.5	12.1	36.9	15.2	44.3	18.5	55.4	23.8	66.4	30.1	
-35		21.0	10.1	26.2	12.6	31.4	15.3	39.3	19.6	47.1	24.5	
35		10	175.3	21.4	219.1	27.5	262.9	34.4	328.7	46.7	394.4	63.1
		5	146.2	21.8	182.8	27.9	219.3	34.6	274.1	46.3	329.0	61.2
	0	120.7	21.7	150.9	27.5	181.1	33.7	226.3	44.6	271.6	58.2	
	-5	98.4	21.1	123.0	26.4	147.6	32.2	184.5	42.1	221.5	54.5	
	-10	79.1	20.1	98.9	25.0	118.7	30.2	148.4	39.1	178.0	50.6	
	-15	62.5	18.7	78.2	23.1	93.8	27.8	117.3	35.9	140.7	46.4	
	-20	48.3	16.9	60.4	20.8	72.5	25.1	90.6	32.4	108.7	41.7	
	-25	36.4	14.5	45.5	18.2	54.6	22.0	68.2	28.4	81.9	36.1	
	-30	26.5	12.1	33.1	15.3	39.7	18.6	49.6	23.9	59.5	30.0	
	40	10	166.2	24.5	207.7	31.4	249.3	39.0	311.6	52.3	373.9	69.5
		5	138.1	24.5	172.7	31.1	207.2	38.2	259.0	50.7	310.8	66.3
		0	113.6	23.9	142.0	30.1	170.4	36.7	213.0	48.1	255.6	62.4
-5		92.1	22.9	115.2	28.6	138.2	34.6	172.8	45.0	207.3	58.1	
-10		73.6	21.6	92.0	26.6	110.4	32.1	138.0	41.5	165.6	53.7	
-15		57.7	19.7	72.2	24.3	86.6	29.2	108.2	37.7	129.9	48.7	
-20		44.2	17.3	55.2	21.5	66.3	26.0	82.8	33.6	99.4	43.0	
-25		32.8	14.6	41.0	18.4	49.3	22.4	61.6	28.9	73.9	36.3	
-30		23.5	12.2	29.4	15.3	35.2	18.5	44.0	23.7	52.8	29.7	

(to be continued overleaf)